

electrical actuators

SRS Series

Twin Square Rail Ball Screw Gantry System

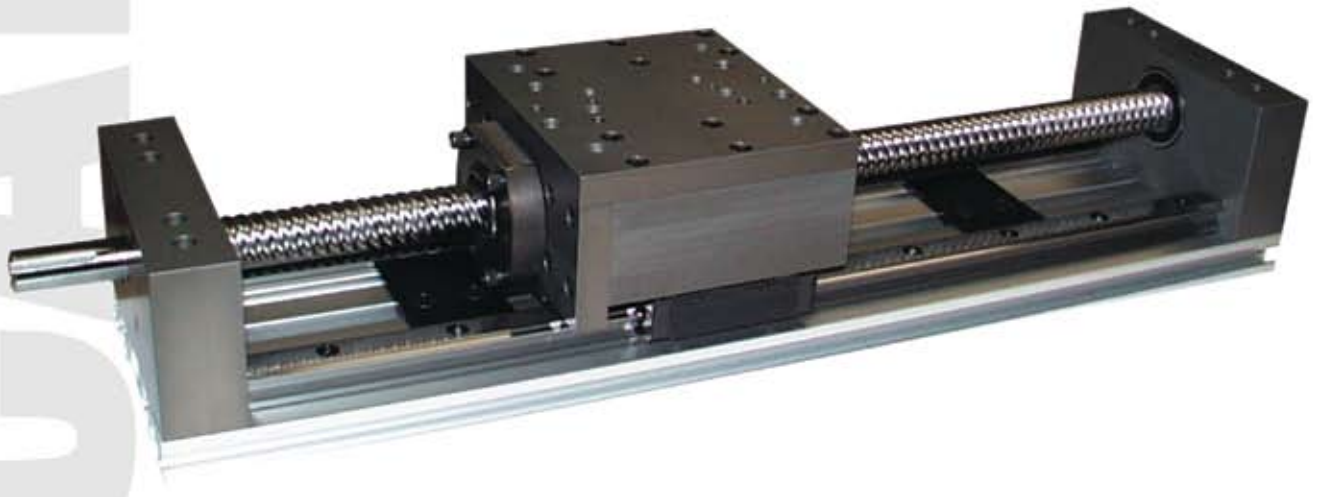

numatics®

Table of Contents



SRS Series	3-6
Features and Benefits	3
How to Order	4
Technical Specifications	4
Critical Speed	4
Dimensions	5
Load Ratings	5
Application Request for Belt and Screw Driven Products	6



SRS - Twin Square Rail Ball Screw Gantry System

- * The ball screw gantry provides precise positioning and high load carrying capacity.
- * Thrust loads up to 7600 lbs.
- * Suitable for mounting in any position; horizontal, vertical, on an incline, or inverted.
- * Low torque required to drive the load due to high efficiency ball screw.
- * Linear bearings provide low stick slip for precise positioning and ease of moving the load.
- * Precision linear rail system supports the load through the entire stroke length.
- * Rugged aluminum extrusion supports the linear rail system through the entire stroke length.
- * Motor mounting for all NEMA 34 and 42 frame motors.
- * NEMA standard gearheads mount directly to the unit.
- * Stroke lengths to 11 feet.
- * NU-MATE mounting pattern is standard.
- * Minimal deflection due to the square rail support system.
- * Bellows available for severe duty applications.
- * Recirculating twin ball tracks in the screw and on the rails provide greater accuracy.
- * Load locking spring prevents load from free falling in the event the ball bearings are lost from the nut.
- * Brush wipers prevent contaminants from entering the nut.

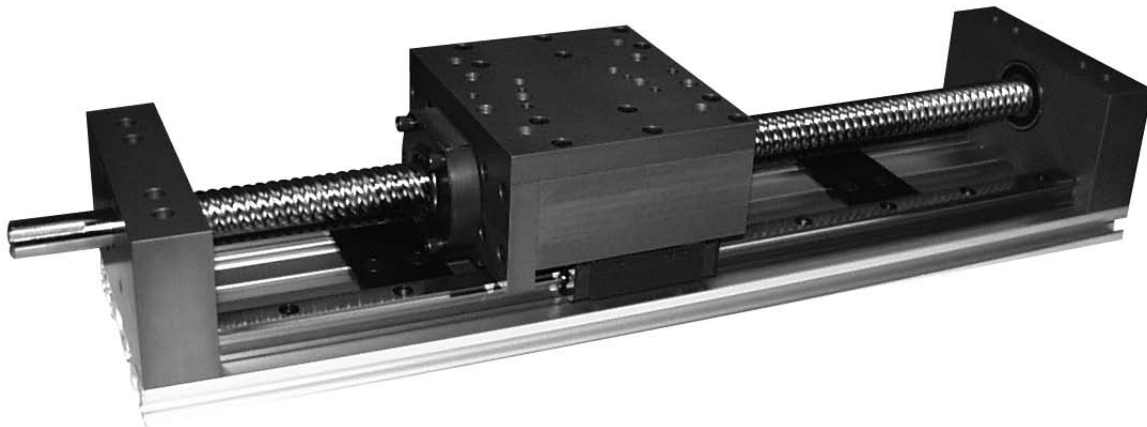



SRS Series

How to Order

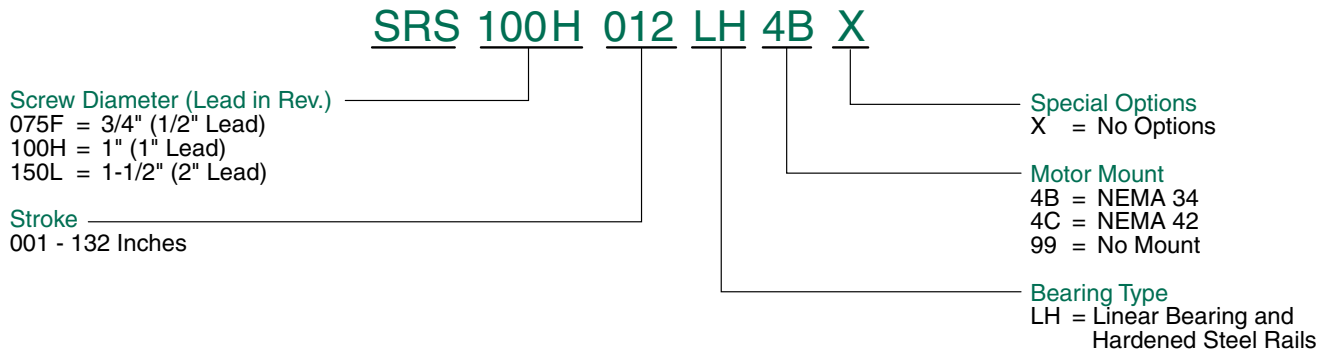

SRS Series Technical Specifications

DESCRIPTION	SRS075	SRS100	SRS150
Maximum Stroke	5 feet	11 feet	11 feet
Maximum Thrust Load-Dynamic	870 lbs.	3450 lbs.	5200 lbs.
Accuracy	+/- 0.005	+/- 0.005	+/- 0.005
Repeatability	+/- 0.005	+/- 0.005	+/- 0.005
Screw Diameter	0.750	1.00	1.425
Screw Lead	0.500	1.00	2.000
Overall Length	9.22+stroke	12.31+stroke	12.31+stroke

Critical Speed Calculations

Note: 3000 RPM Max.

SRS075F

$$1 \times (4.76 \times 10^6) \times \left(\frac{0.697}{(\text{Stroke} + 6.74)^2} \right) = A \quad A \times 0.8 = B \quad \frac{B}{60} = C \quad C \times 0.5 = \text{In./Sec.}$$

SRS100H

$$1 \times (4.76 \times 10^6) \times \left(\frac{0.911}{(\text{Stroke} + 9.31)^2} \right) = A \quad A \times 0.8 = B \quad \frac{B}{60} = C \quad C \times 1.0 = \text{In./Sec.}$$

SRS150L

$$1 \times (4.76 \times 10^6) \times \left(\frac{1.323}{(\text{Stroke} + 9.31)^2} \right) = A \quad A \times 0.8 = B \quad \frac{B}{60} = C \quad C \times 2.0 = \text{In./Sec.}$$



SRS Series Dimensions

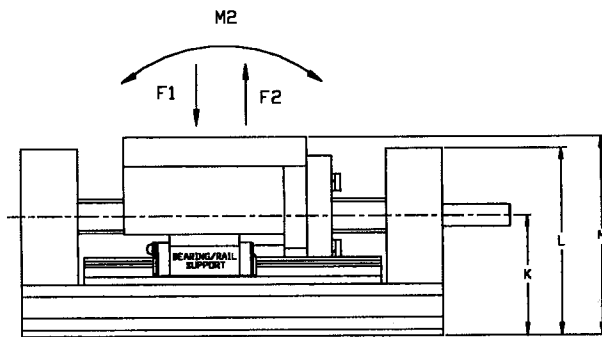
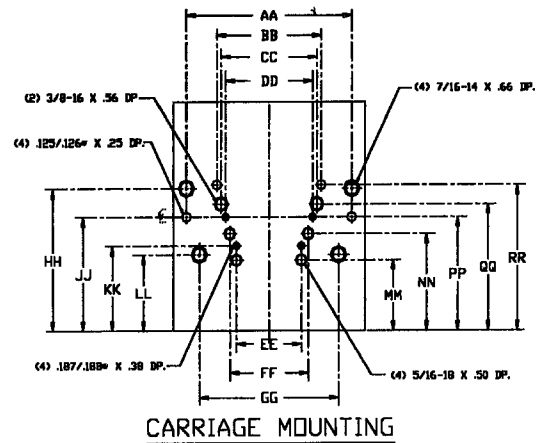
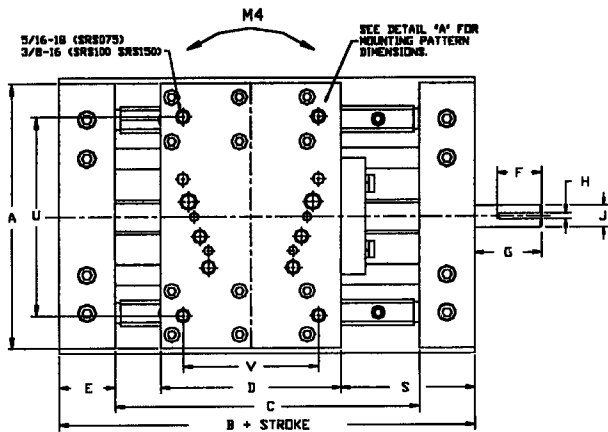

NOTE: UNIT IS DRAWN AT 0° STROKE

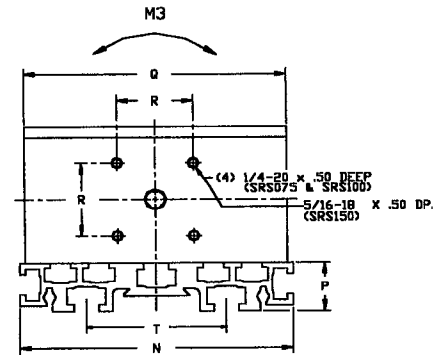

	A	B	C	D	E	F	G	H	J	K	L	M	N	P	Q	R	S	T
SRS075F	6.00	9.22	6.74	4.00	1.24	1.00	1.50	0.125	0.50	2.65	4.13	4.38	6.25	1.13	6.00	1.75	2.98	3.50
SRS100H	6.11	12.31	9.34	5.50	1.50	1.09	2.00	0.187	0.75	3.05	4.30	4.93	6.25	1.13	6.25	1.75	3.91	3.50
SRS150L	6.25	12.31	9.31	6.00	1.50	1.58	2.50	0.250	1.00	3.23	5.13	5.76	6.25	1.13	6.25	1.80	3.81	3.50

	U	V	AA	BB	CC	DD	EE	FF	GG	HH	JJ	KK	LL	MM	NN	PP	QQ	RR
SRS075F	3.00	3.00	-	3.00	2.75	2.50	1.87	2.25	-	-	3.05	2.29	-	1.91	2.61	3.05	3.40	3.90
SRS100H	4.00	4.00	4.75	3.00	2.75	2.50	-	2.25	4.00	3.80	3.05	-	2.05	-	2.61	3.05	3.40	3.90
SRS150L	4.00	4.00	4.75	3.00	2.75	2.50	-	2.25	4.00	3.80	3.13	-	2.13	-	2.34	2.78	3.13	3.63

Moment Load Rating

	SRS075F	SRS100H	SRS150L
F1	4859 lbs	11,448 lbs	16,524 lbs
F2	2998 lbs	7667 lbs	9792 lbs.
M2	990 in/lbs	3823 in/lbs	6514 in/lbs
M3	1416 in/lbs	4389 in/lbs	7222 in/lbs
M4	990 in/lbs.	3823 in/lbs	6514 in/lbs



SRS Series

Application Request Form for Belt and Screw Driven Electrical Products

Your Name: _____ Company Name: _____

Phone: _____ Fax: _____ Date: _____

Please Complete the required info in each step:

Stroke (inches): _____ **Load** (pounds): _____ -and/or- **Opposing Force** (pounds): _____

Repeatability: +/-0.005 inches (Screw Drive): -or- +/-0.012 inches (Belt Drive):

Actuator Orientation: Horizontal: -or- Vertical: *Note: Belt Drive Product is not recommended for Vertical Applications*

Check box if carriage is face DOWN: _____ -and/or- Include Degree of Incline: _____°

Check one:

A) Load is supported by Actuator: (if no skip to STEP 4)

B) Load is pushed by Actuator:

If load is pushed: 1) What supports the load? _____

2) Coefficient of friction? _____

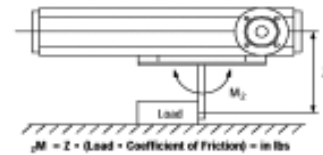

Moment Loading

Check one of the Following:

A) A Moment Condition does not occur: (if so skipt to STEP 5)

B). A Moment Condition does occur:

CIRCLE ONE of the following conditions and provide the following information:

Arm Length (inches): _____

Force (pounds): _____

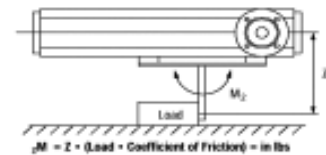
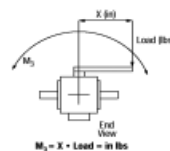
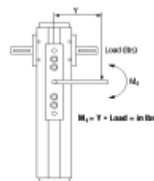

Speed/Cycle Time *Fill out as much information as possible. Must include a move distance and at least 1 other input.*

Move Distance: _____ inches

Velocity: _____ in/sec

Acceleration: _____ in/sec²

Time: _____ sec

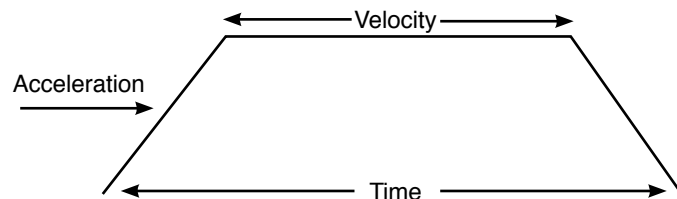

Note: Provide Move Distance and at least 1 other input

If there are multiple stops, check here: and provide Move Distance and at least one other input per stop in the space below:

Total Package? Please check all that apply: Motor & Controller Package: Brake:

Customers Controller or PLC will supply host commands: Encoder/Closed Loop:

NUMATICS

*World Class Supplier
of Pneumatic Components*

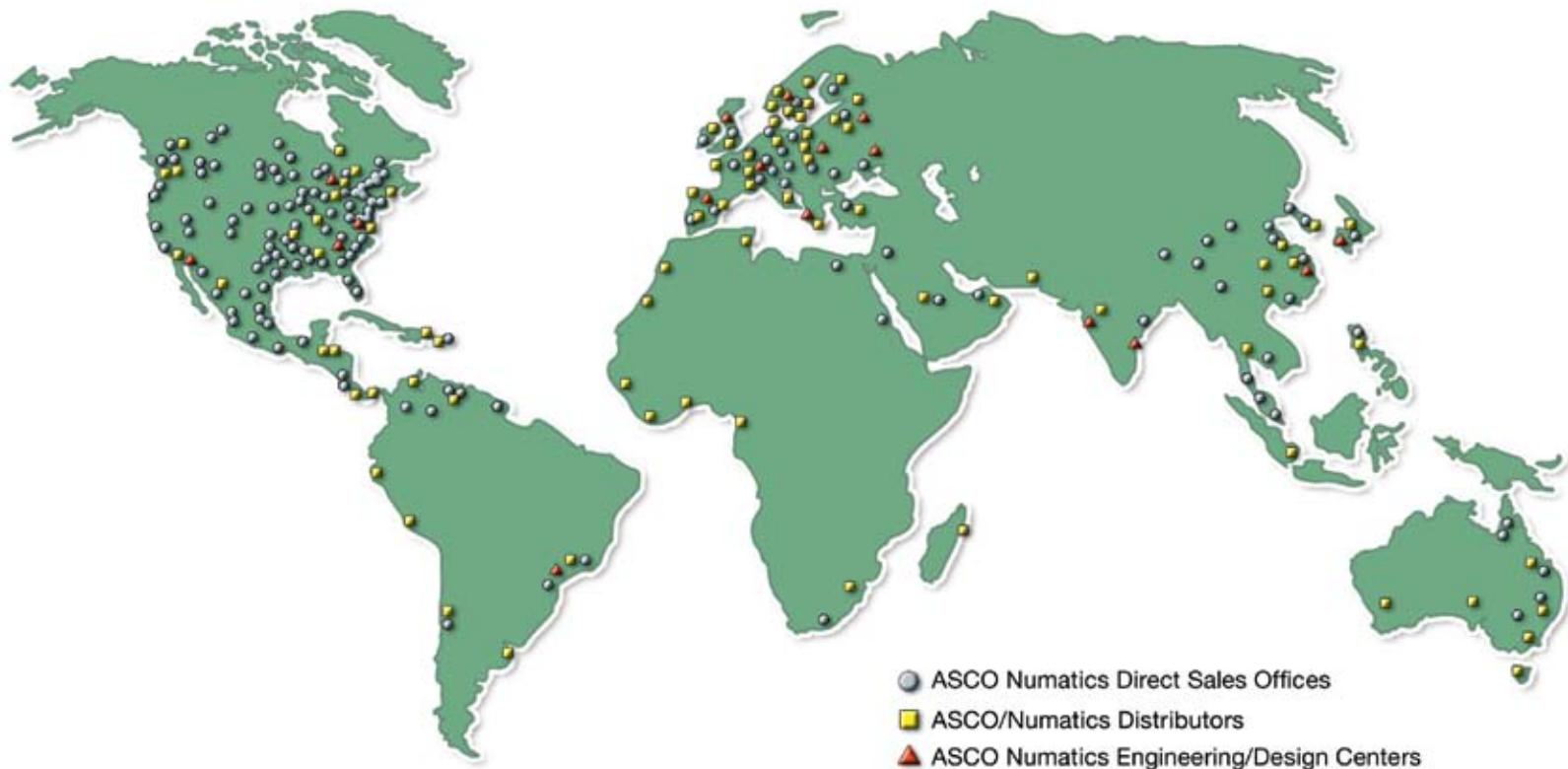

WORLD HEADQUARTERS

USA

Numatics, Incorporated

46280 Dylan Drive
Novi, Michigan 48377

P: 1-888-Numatics
1-888-686-2842

Canada

Numatics, Ltd

P: 519-452-1777

Mexico

Numatics de Mexico S.A. de C.V.

P: 52-222-284-6176

For a comprehensive listing of all Numatics production and distribution facilities worldwide, visit:

www.numatics.com