

electrical actuators

BDU Series
Belt Drive Unit



numatics

<i>BDU</i> Series Belt Driven Units	3-13
Features and Benefits	3
How to Order	4
Dimensions	5-7
BDU Motor Mounts	8-9
NuMate Compatability	10
Technical Specifications	11
Load Ratings	11
Switch Mounting	12
Mounting Brackets	12
Application Request for Belt and Screw Driven Products	13



BDU - Series Belt Driven Units

The BDU-Series is a belt driven guided linear motion system utilizing a tooth-profiled belt to control position of its moving carriage. This belt driven design provides modest load carrying capacity, high speed and very long stroke capabilities. The BDU-Series requires a motor of some type to drive the unit. Motors include stepper, servo, AC/DC synchronous and air drives.

The BDU-Series is designed for moving loads at high speeds over greater distances with relative positioning accuracies. This product has not been designed for precision positioning accuracies. For applications requiring precision positioning, refer to BSG Ball Screw Gantry Series.

NMC does not recommend the BDU-Series in vertical applications.

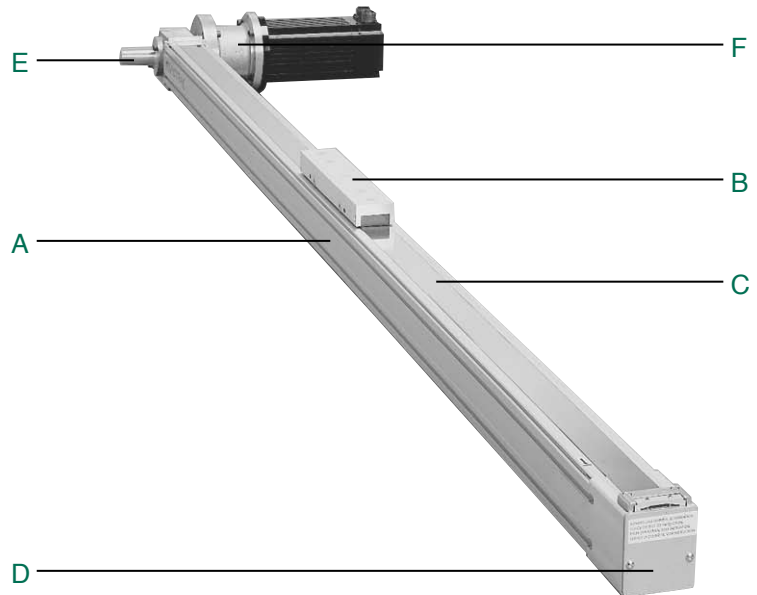

Features and Benefits:

A. Body:

- Body Profile extruded aluminum, rigid, light weight
- Rigid Design internal stiffening ribs support carriage
- Side Slots for position switch mounting and foot mounting brackets

B. Carriage:

- Guided and Supported body extrusion geometry supports carriage motion
- Robalon™ Bearings synthetic bearing material for high speed applications
- Thread Inserts secure mounting for high speed application
- NuMate™ Direct Mounting Pattern other Numatics Motion Control products mount directly to carriage without adapters or transition plates
- increased flexibility, cost and time savings

C. Drive Belt:

- Steel Reinforced Polyurethane light weight, high strength, low stretch
- Trapezoid Profile eliminates slip, greater accuracy
- Belt Cover protects belt from contamination, not available on the BDU50 Series

D. End Cap:

- Belt Tensioning System easy access, easy adjustment

E. Output Shaft:

- Dual Output Shaft accessible from both sides of body, motor mounting from both sides
- Protective Cover molded plastic, covers rotating shaft end opposite of motor, protects

F. Motor Mount Assembly:

- Cast Motor Flange for NEMA 23, 34 and 42 frame motors



BDU Series Belt Driven Units

NUMATICS®

How to Order

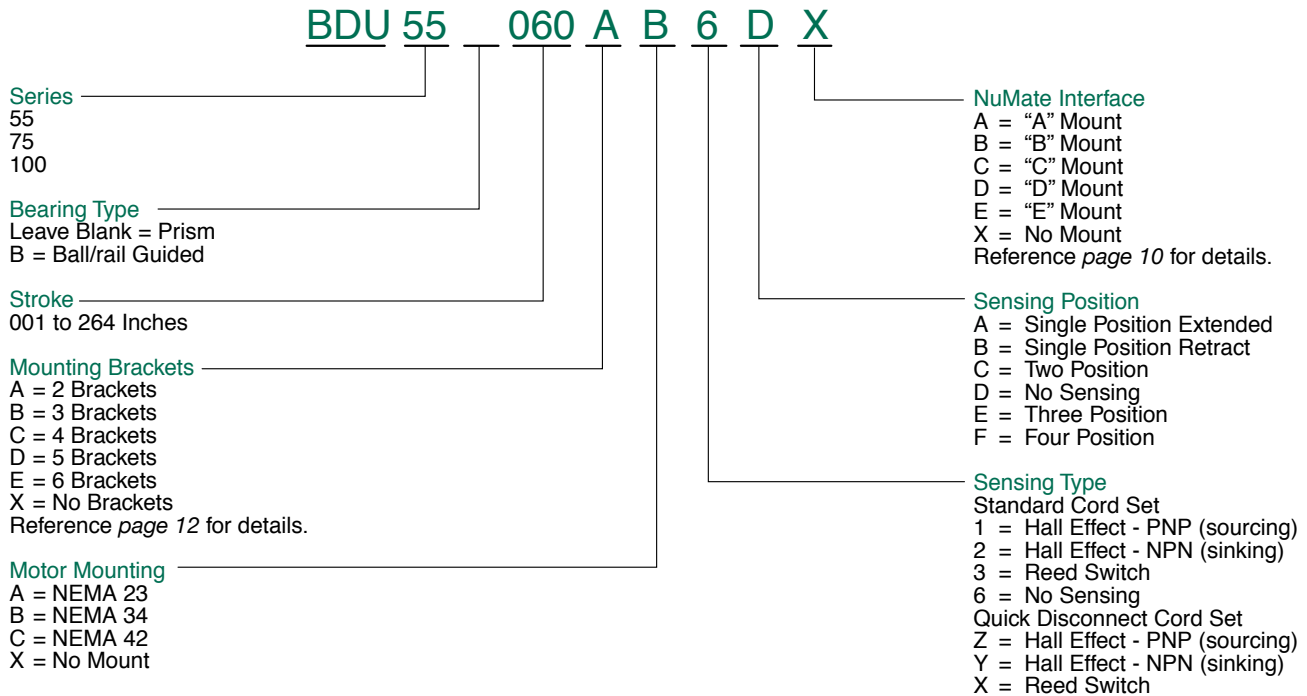

Example order:

Part Number: BDU55060BB6DX*
 Part Description: 55 Series with 60 inch stroke, 3 mounting brackets, NEMA 34 motor mounts, no sensing, and no NuMate interface.

* When entering an order, DO NOT use spaces or dashes.

When Ordering Additional Sensors, Mounting Kits, or Shocks

SWITCH DESCRIPTION	STANDARD PART NO.	QUICK DISCONNECT PART NO.
Hall Effect - PNP (Sourcing)	HPNPS31	HPNPQ31
Hall Effect - NPN (Sinking)	HNPNS32	HNPNQ32
Reed Switch	RSS02	RSQ02
90° 5 meter cable	-	PXC90
Straight 5 meter cable	-	PXCST

SERIES SLIDE	BASE MOUNT	ANGLE MOUNT	SHOCK ABSORBER
SH031	MB031	AB031	-
SH056	MB056	AB056	-
SH075	MB075	AB075	SK106
SH106	MB106	AB106	SK106
SH150	MB150	AB150	SK150
SH200	MB200	AB200	SK200
SH250	-	AB200	SK250
SH300	-	-	SK300



BDU 55 Series Dimensions

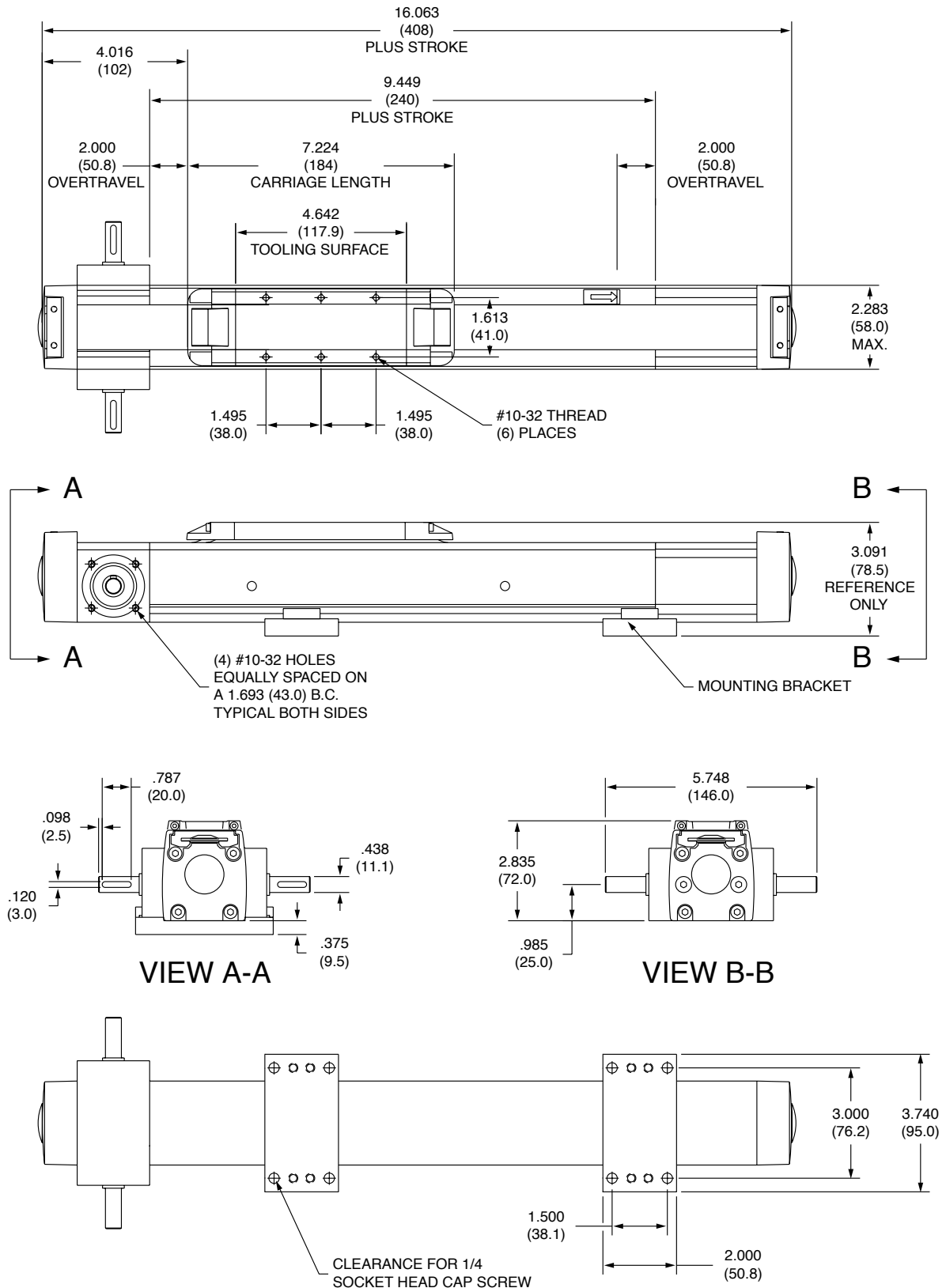



BDU Series Belt Driven Units

NUMATICS®

BDU 75 Series Dimensions

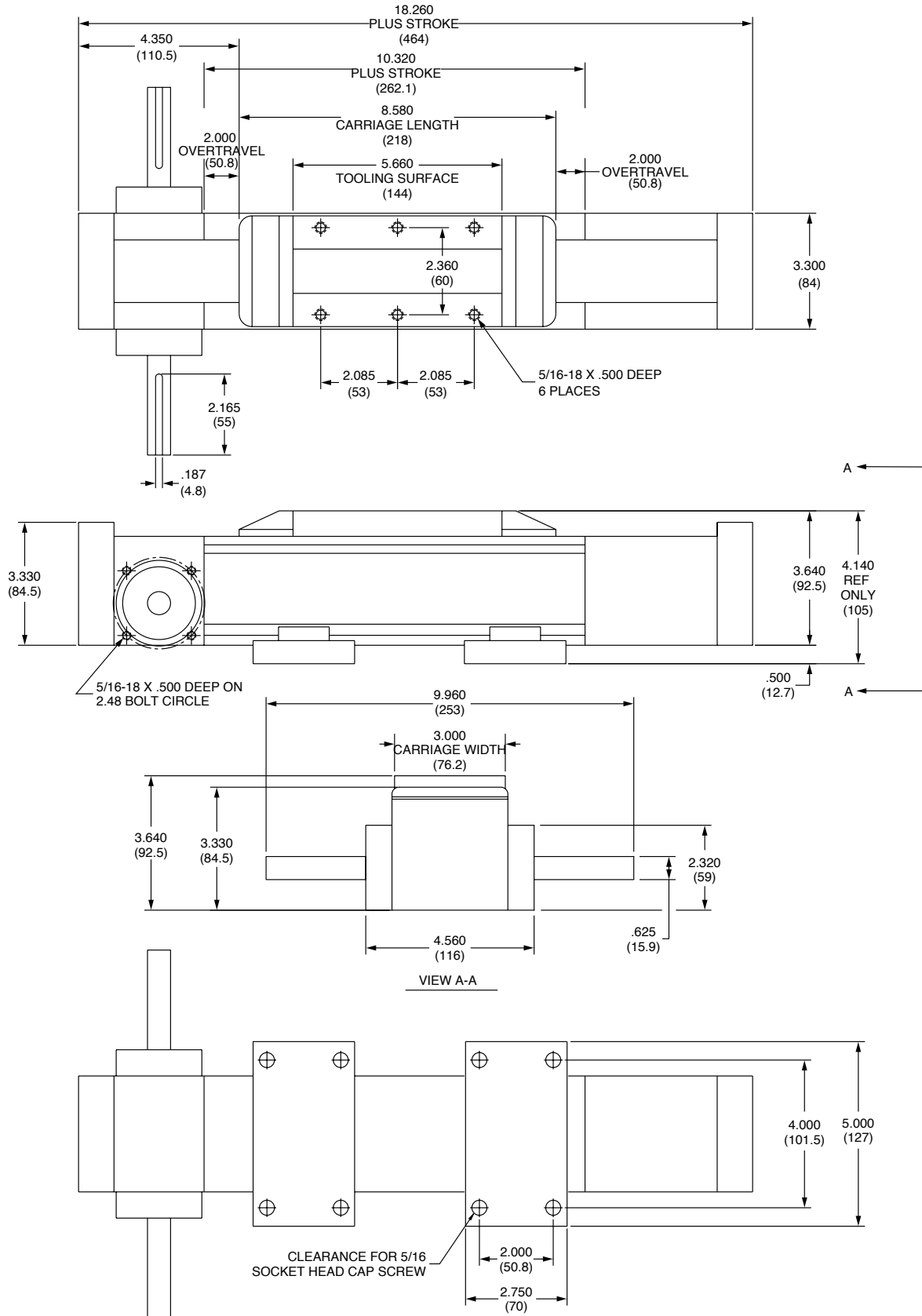



BDU 100 Series Dimensions

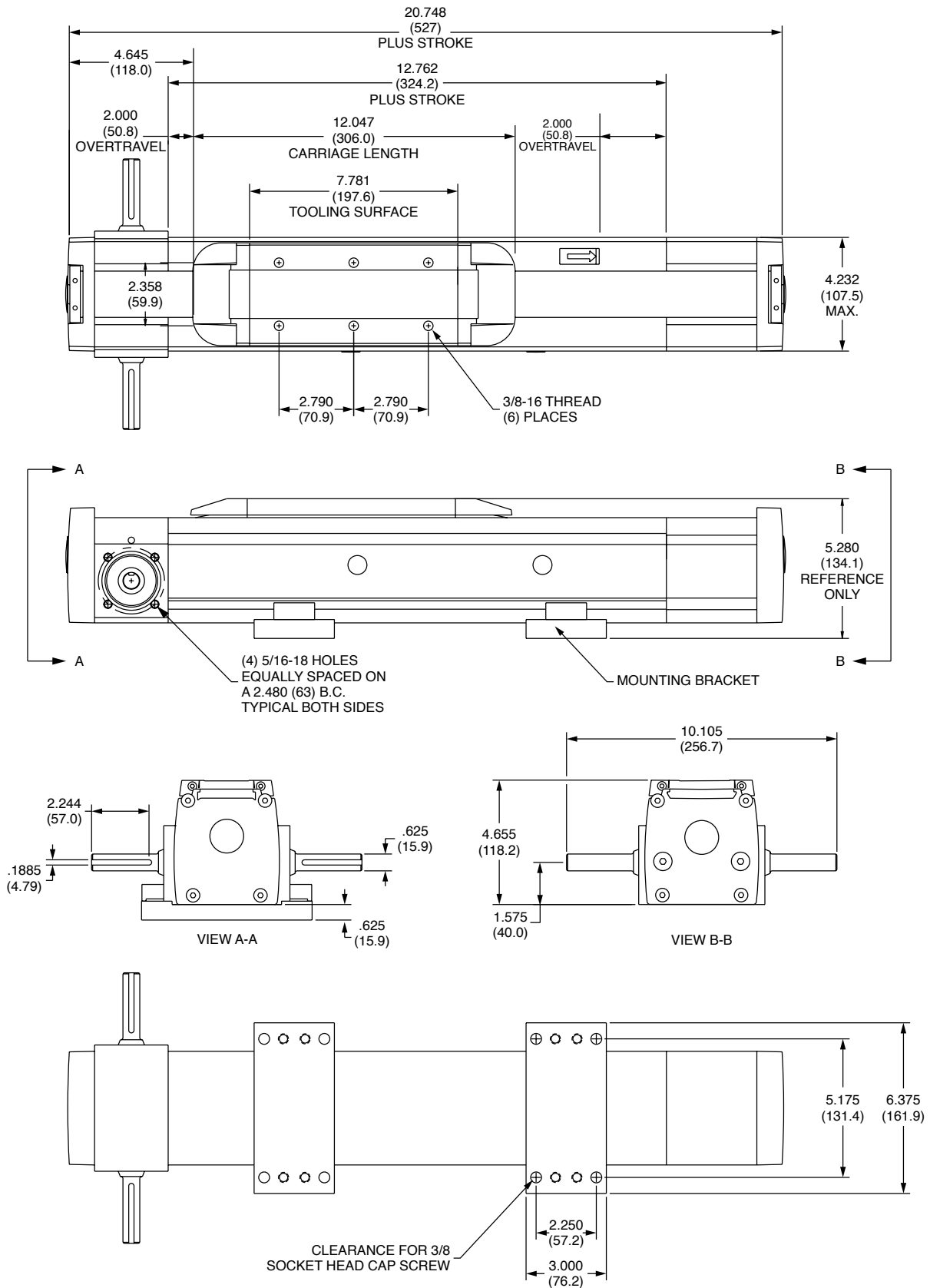



BDU Series Belt Driven Units

NUMATICS®

BDU Motor Mountings

BDU 55 NEMA 23

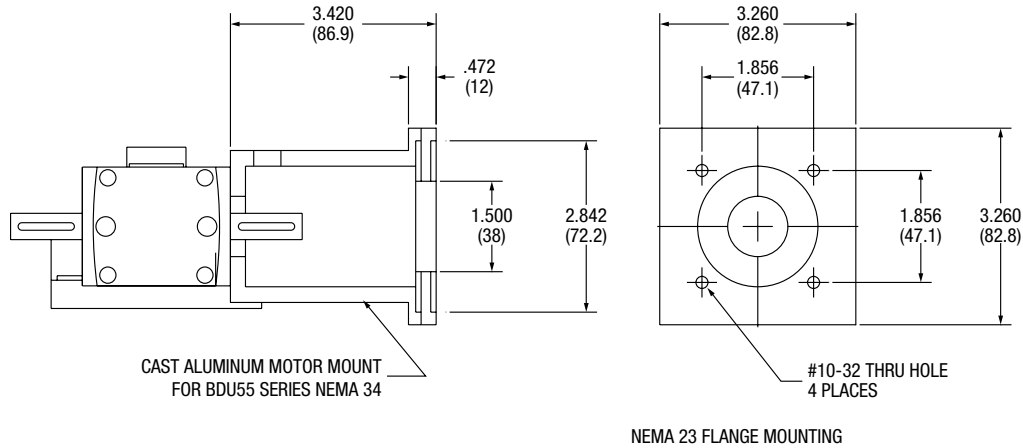

BDU 55 NEMA 34

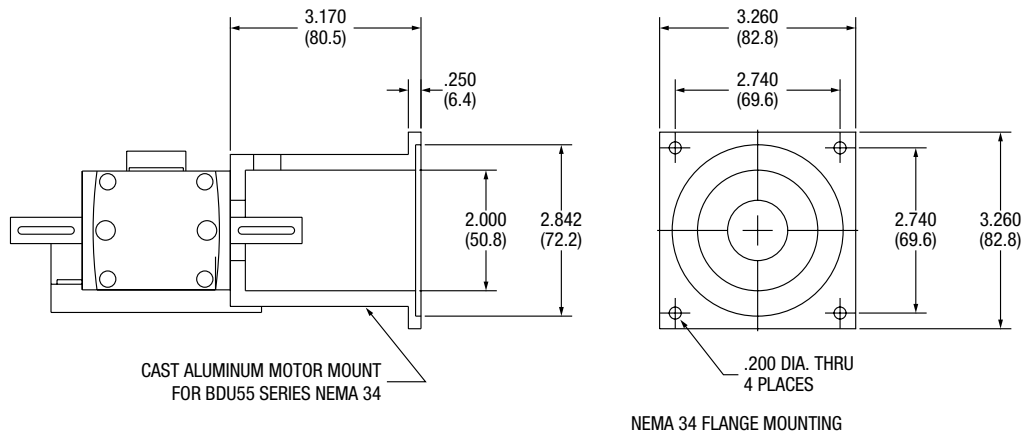

BDU 75 NEMA 34

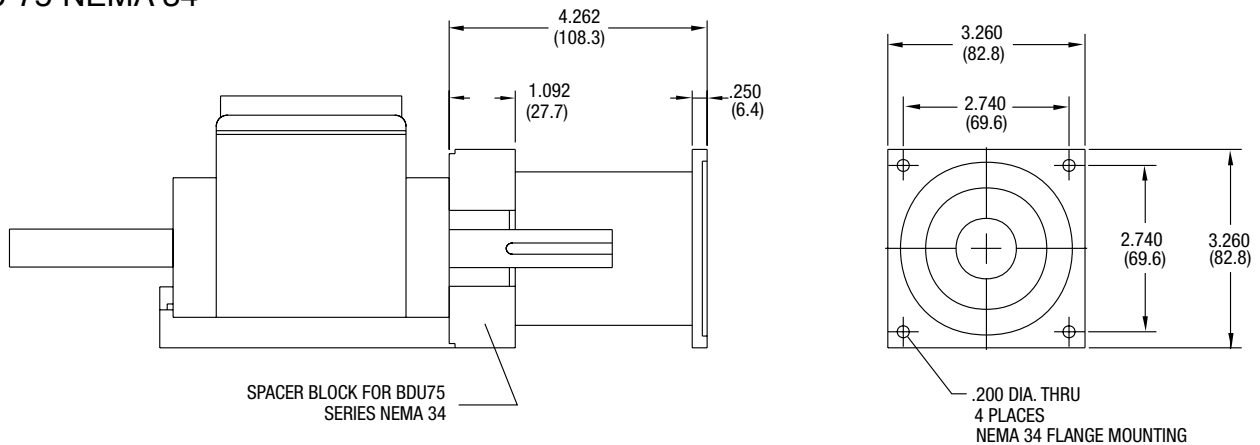



BDU Motor Mountings continued

BDU 75 NEMA 42

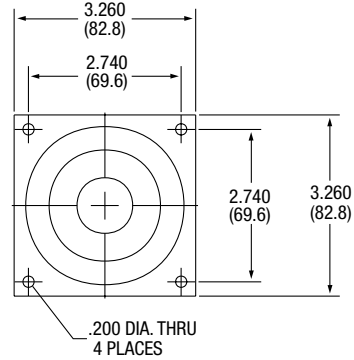
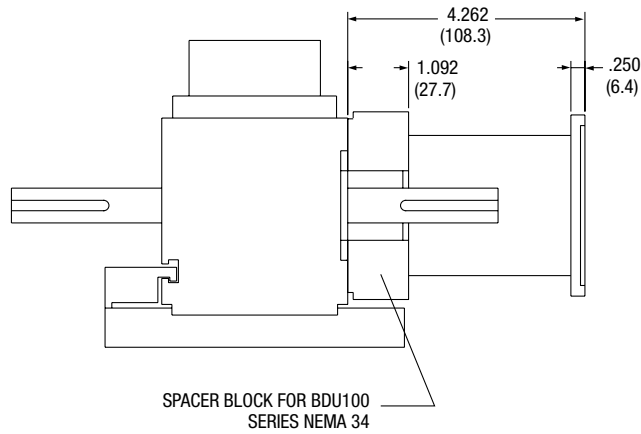

NEMA 34 FLANGE MOUNTING

BDU 100 NEMA 34

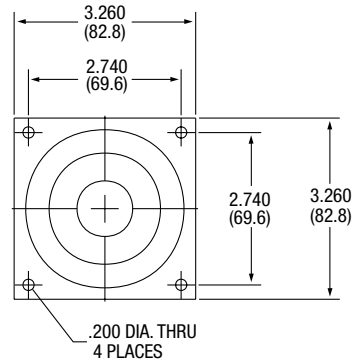
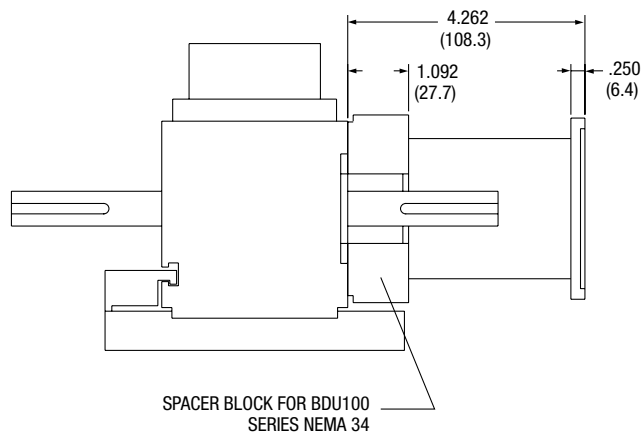

NEMA 34 FLANGE MOUNTING

BDU 100 NEMA 42

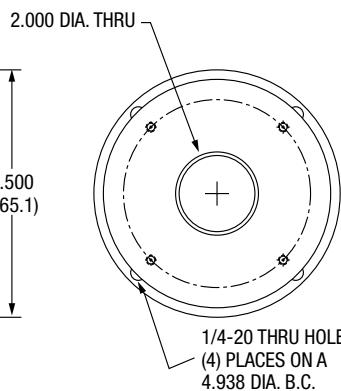
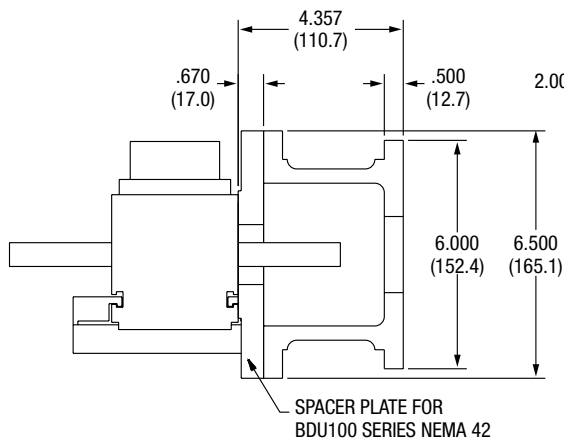

NEMA 42 FLANGE MOUNTING



BDU Series Belt Driven Units

NUMATICS®

BDU-Series *NuMate™* Mounting

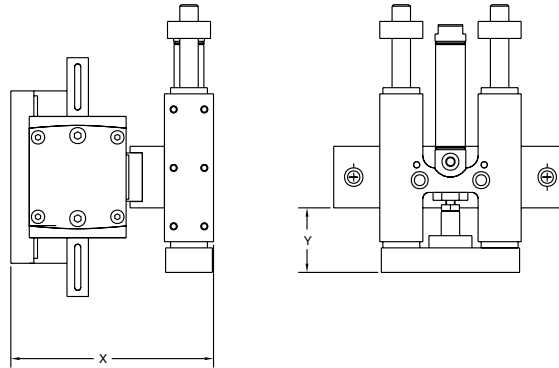

SLIDE	NUMATE MOUNTING CODE	BDU55		BDU75		BDU100	
		X	Y	X	Y	X	Y
SH056	"A" Mount	4.400	0.830	-	-	-	-
SH075	"B" Mount	1.710	1.710	6.117	0.717	-	-
SH106	"C" Mount	-	-	6.492	1.285	-	-
SH150	"D" Mount	-	-	6.868	1.613	7.660	1.210
SH200	"E" Mount	-	-	-	-	8.160	1.960
SH250	"E" Mount	-	-	-	-	8.530	1.900

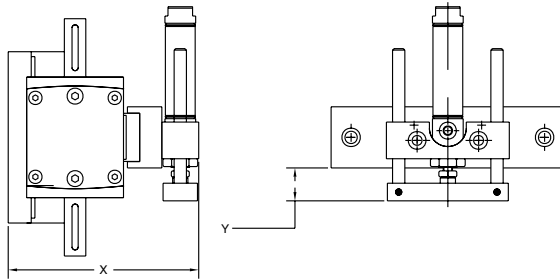

SLIDE	NUMATE MOUNTING CODE	BDU55		BDU75	
		X	Y	X	Y
LC056	"A" Mount	4.155	0.094	-	-
LC075	"B" Mount	4.385	0.454	-	-
LC106	"C" Mount	-	-	6.312	0.218
LC150	"D" Mount	-	-	6.619	0.437

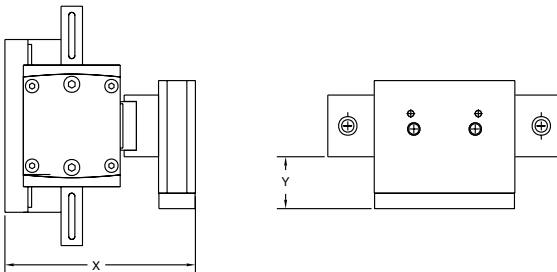

SLIDE	NUMATE MOUNTING CODE	BDU55		BDU75	
		X	Y	X	Y
B04	"A" Mount	4.221	0.483	-	-
B06	"A" Mount	4.411	0.644	-	-
B08	"A" Mount	-	-	-	-



BDU Series Technical Specifications

DESCRIPTION	BDU 55	BDU 75	BDU 100
Maximum Speed	196 in/sec	196 in/sec	196 in/sec
Maximum Stroke	22 feet	22 feet	22 feet
Maximum RPM	2300 rpm	2300 rpm	2500 rpm
Maximum Belt load	90 lbs.	130 lbs.	281 lbs
Drive Ratio	4.13 in/rev	5.11 in/rev	6.93 in/rev
Tooth Pitch	0.1968 in	0.1968 in	0.315 in.
Tooth Pitch Error	0.0096 in/ft cum.	0.0096 in/ft cum.	0.0096 in/ft cum.
Positioning Accuracy	+/- 0.010 in/ft	+/- 0.010 in/ft	+/- 0.010 in/ft
Repeatability	+/- 0.012 in	+/- 0.012 in	+/- 0.012 in
Carriage Weight	2.43 lbs.	4.4 lbs.	4.85 lbs.
Radial Load on Input Shaft	61 lbs.	134 lbs.	225 lbs.
Torsional Load on Output Shaft	13 ft.-lbs.	22 ft.-lbs.	33 ft.-lbs
Drive Pulley Diameter	1.32 in.	1.63 in.	2.3 in.
Drive Pulley Weight	0.132 lbs.	0.28 lbs.	0.813 lbs.
Driven Pulley Diameter	1.32 in.	1.50 in.	2.3 in.
Driven Pulley Weight	0.132 lbs.	0.24 lbs.	0.813 lbs.
Belt Width	0.75 in.	1.57 in.	1.97 in.
Belt Weight	0.135 lbs./ft.	0.4 lbs./ft.	1.511 lbs./ft.
Belt Material	Steel reinforced polychloropren	Steel reinforced polyurethane	Steel reinforced polyurethane
Belt Length	22.4 in + Stroke	44.2 in + Stroke	44.282 in + Stroke
Maximum Humidity	80% Standard	80% Standard	80% Standard
Operating Temperature	0 to 158 F	0 to 158 F	0 to 158 F
Base Weight	8.9 lbs.	13.2lbs.	25.4 lbs.
Adder per inch of Stroke	0.3 lbs.	0.4 lbs.	0.6 lbs

Example: BDU55 with 12" stroke $8.9 + (0.3 \times 12) = 12.5$ lbs.

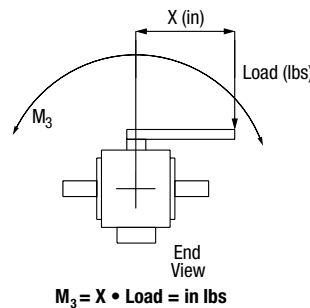
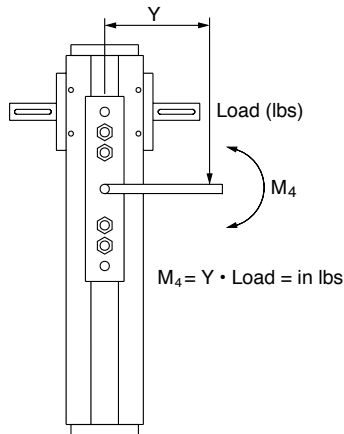
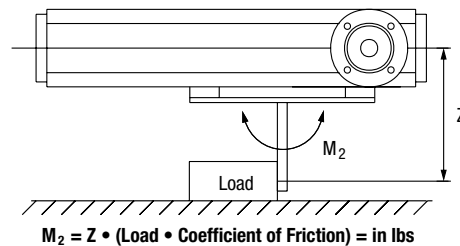
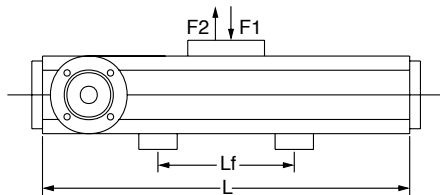

BDU Maximum Load Capacities

CONFIGURATION	BDU 55	BDU 55B	BDU 75	BDU 75B	BDU 100	BDU 100B
F1	88	165	319	374	660	880
F2	55	105	180	239	480	563
M2	203	185	708	708	2389	2478
M3	79	56	398	132	885	442
M4	79	56	398	132	885	442



**BDU Series
Belt Driven Units**

NUMATICS®

Switch Mounting

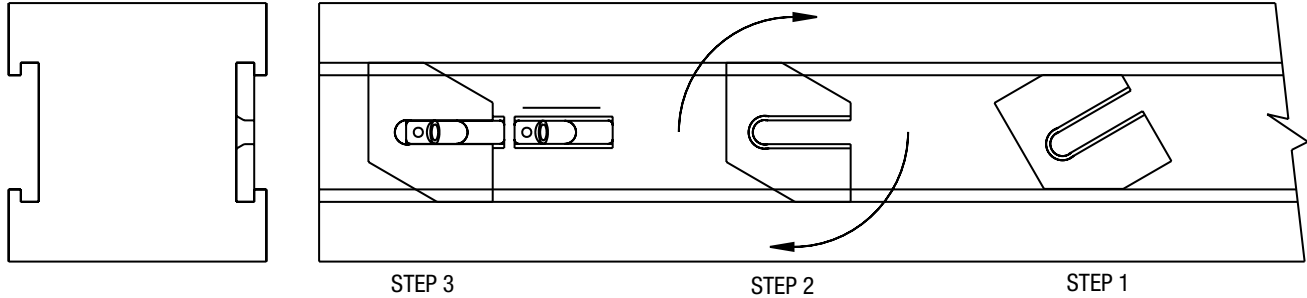

POSITION SWITCH MOUNTING BRACKET FOR NUMATICS SENSORS

Mounting Brackets

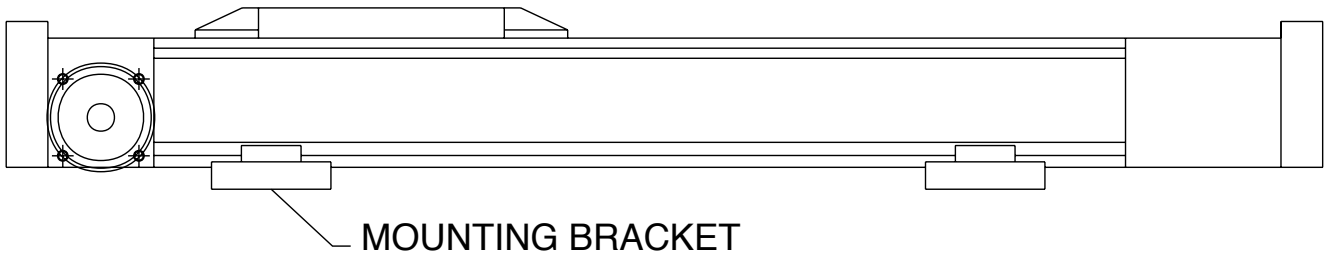

Mounting Brackets Required

BDU SERIES	BDU 55	BDU 75	BDU 100
STROKE/SUPPORTS REQ'D			
1" to 48"	2	2	2
49" to 84"	3	3	3
85" to 132"	4	4	3
133" to 180"	5	5	4
181" to 240"	6	6	5



Application Request Form for Belt and Screw Driven Electrical Products

Your Name: _____ Company Name: _____

Phone: _____ Fax: _____ Date: _____

Please Complete the required info in each step:

Stroke (inches): _____ **Load** (pounds): _____ -and/or- **Opposing Force** (pounds): _____

Repeatability: +/-0.005 inches (Screw Drive): -or- +/-0.012 inches (Belt Drive):

Actuator Orientation: Horizontal: -or- Vertical: *Note: Belt Drive Product is not recommended for Vertical Applications*

Check box if carriage is face DOWN: -and/or- Include Degree of Incline: _____°

Check one:

A) Load is supported by Actuator: (if no skip to STEP 4)

B) Load is pushed by Actuator:

If load is pushed: 1) What supports the load? _____

2) Coefficient of friction? _____

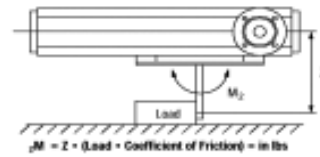

Moment Loading

Check one of the Following:

A) A Moment Condition does not occur: (if so skip to STEP 5)

B). A Moment Condition does occur:

CIRCLE ONE of the following conditions and provide the following information:

Arm Length (inches): _____

Force (pounds): _____

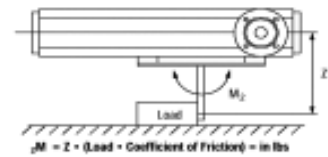
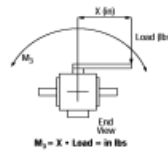
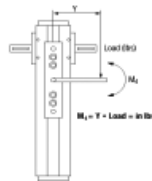

Speed/Cycle Time Fill out as much information as possible. Must include a move distance and at least 1 other input.

Move Distance: _____ inches

Velocity: _____ in/sec/

Acceleration: _____ in/sec²

Time: _____ sec

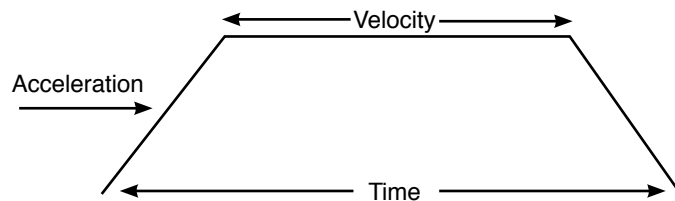

Note: Provide Move Distance and at least 1 other input

If there are multiple stops, check here: and provide Move Distance and at least one other input per stop in the space below:

Total Package? Please check all that apply: Motor & Controller Package: Brake:

Customers Controller or PLC will supply host commands: Encoder/Closed Loop:

NUMATICS

*World Class Supplier
of Pneumatic Components*

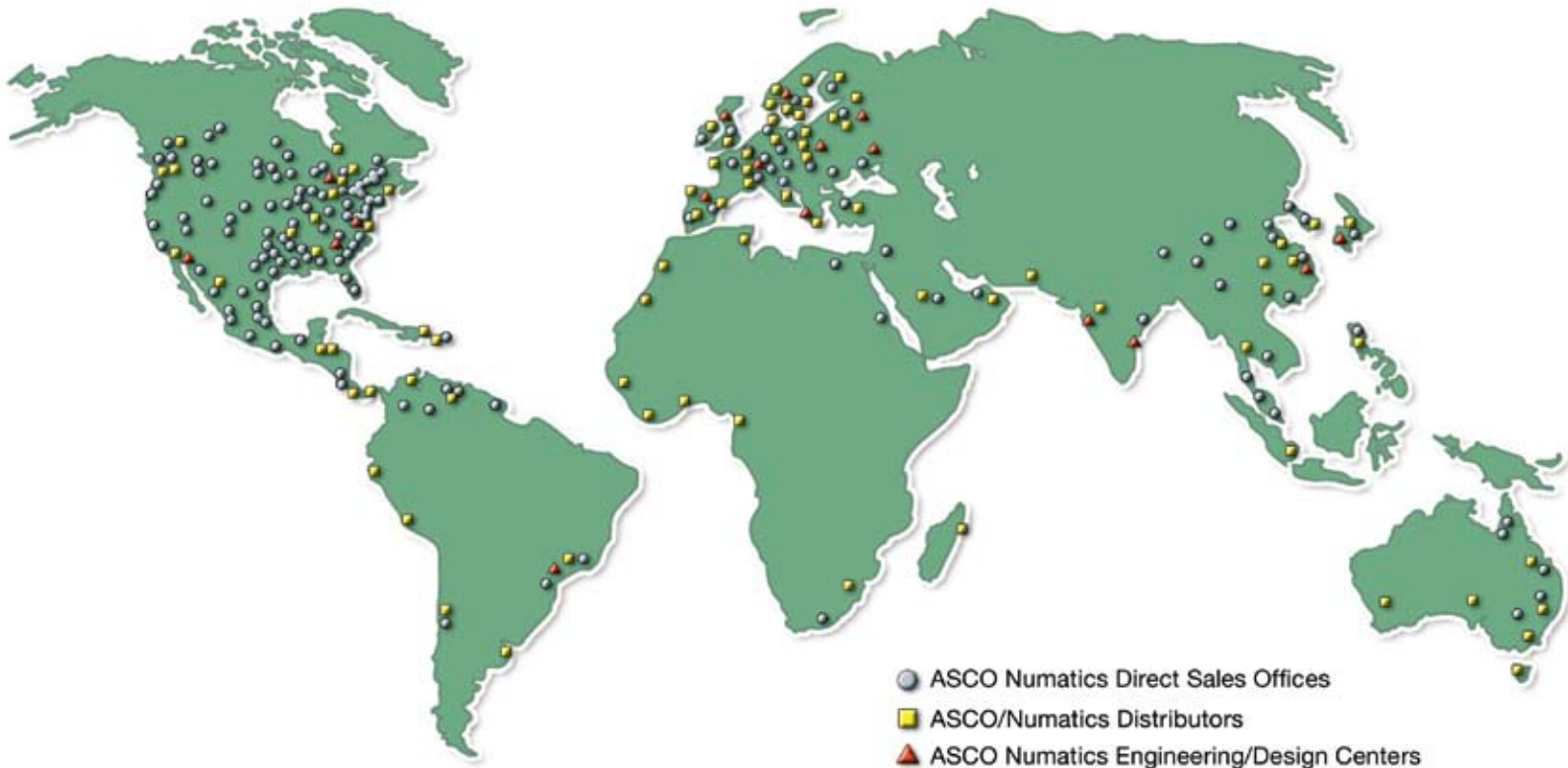

WORLD HEADQUARTERS

USA

Numatics, Incorporated

46280 Dylan Drive
Novi, Michigan 48377

P: 1-888-Numatics
1-888-686-2842

Canada

Numatics, Ltd

P: 519-452-1777

Mexico

Numatics de Mexico S.A. de C.V.

P: 52-222-284-6176

For a comprehensive listing of all Numatics production and distribution facilities worldwide, visit:

www.numatics.com